

L6 – Pumping Units

Dr. Elena Vagnoni
elena.vagnoni@epfl.ch

Topics of the lecture

- Why pumped storage power stations?
- Pumped Hydro Technologies
 - Binary or reversible groups
 - Ternary groups
 - Quaternary groups

Role of Hydropower in the grid

Flexibility needs

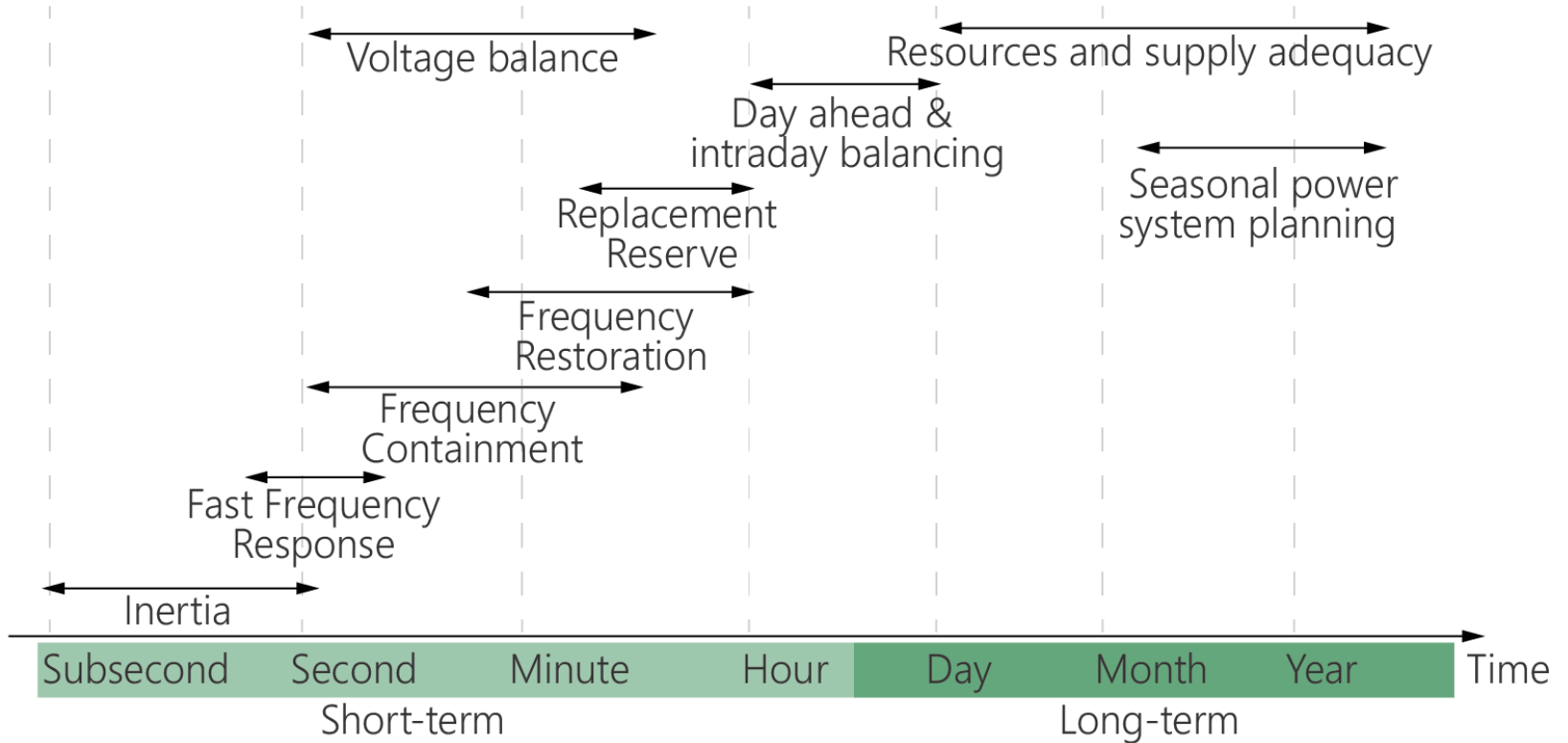

Reasons for Pumped Storage Power Stations

- Electrical energy cannot be directly stored
- Matching the Demand of Energy
- Seasonal, Daily Energy Balance
- Services to the Grid
 - Frequency regulation:
Primary, secondary and tertiary control
 - Voltage regulation
 - Black Start
 - Etc.

Integration of New Renewable Energy Sources in Europe

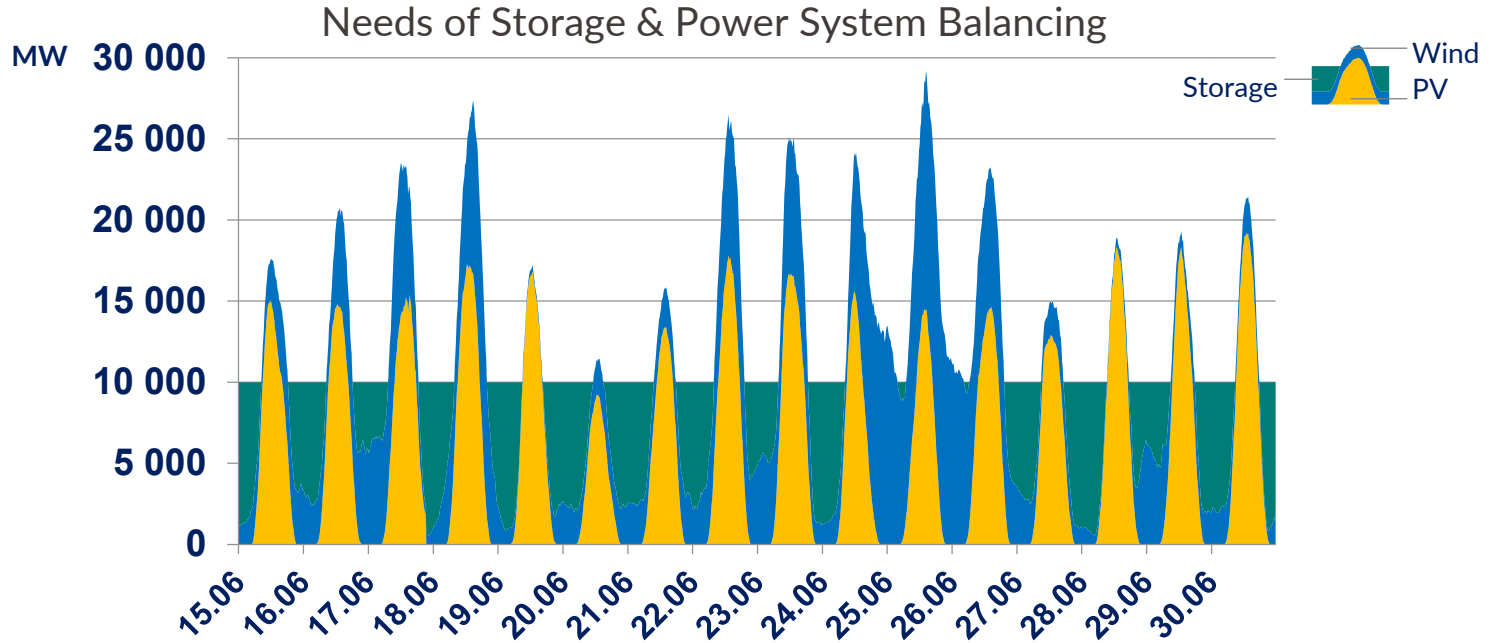

NREs Generation in Germany, Mid of June 2012 : 10 GW Storage Capacity!

Integration of New Renewable Energy Sources: *Swiss Case*

- Storage Hydropower Plants
 - Mainly Pelton Turbines ($\approx 10'000$ MW)
- Pumped Storage Power Plants
 - 3'540 MW Capacity in 2016
- Decommissioning of Gas Fired Thermal Power Plants
 - Phasing out the Nuclear Power Plants;

Legende / Légende / Leggenda

- 10 - < 50 MW (103 Zentralen)
- 50 - < 200 MW (62 Zentralen)
- ▲ ≥ 200 MW (16 Zentralen)

Zentrale einer internationalen Wasserkraftanlage
 Centrale d'un aménagement hydro-électrique international
 Centrale d'un impianto idroelettrico internazionale

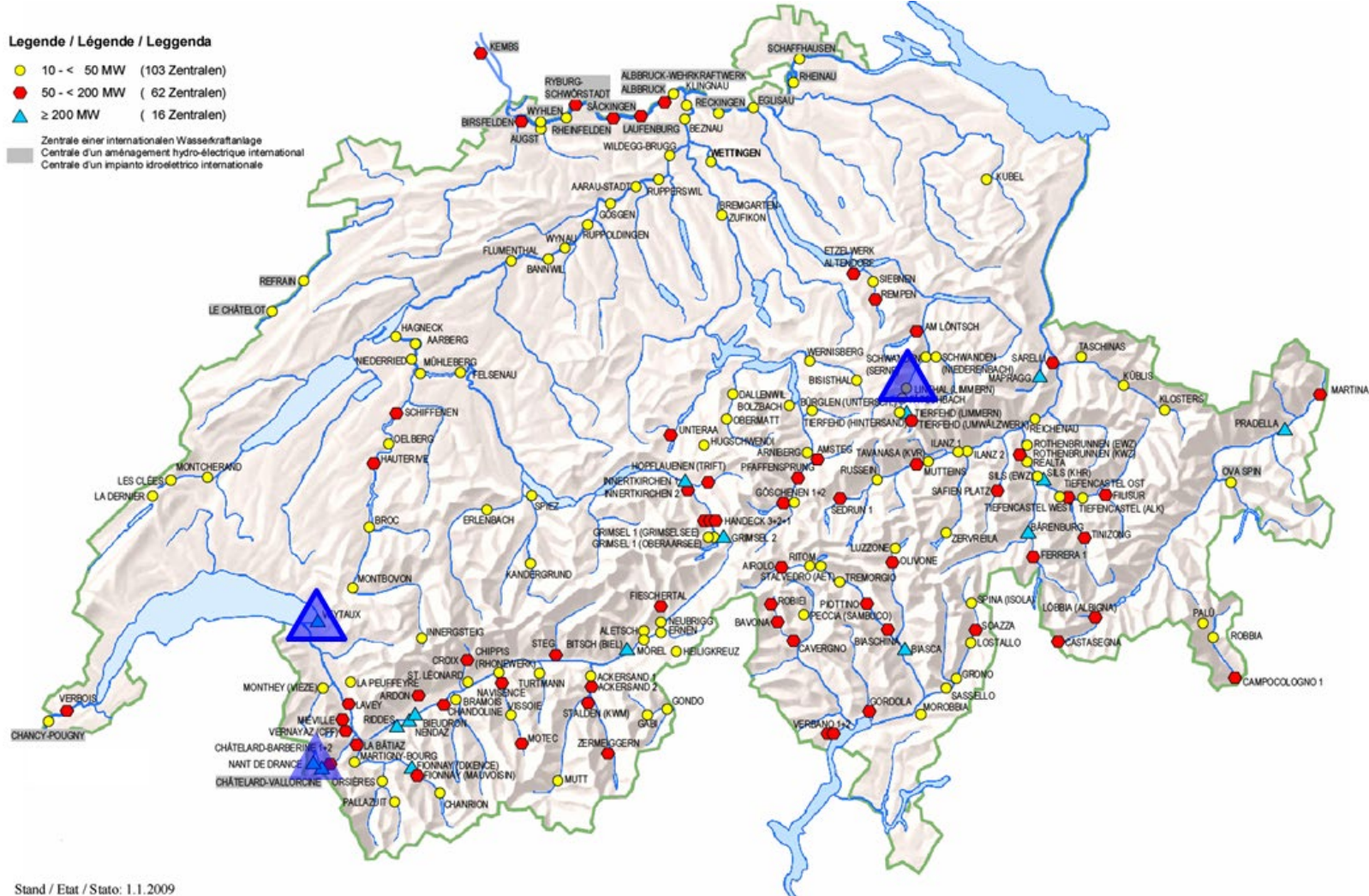

Types of Pumped-storage power plant

- **Binary Group:** unit equipped with reversible pump-turbines
- **Ternary Group:** turbine and pump on the same shaft
- **Quaternary Group:** separated pumping and generating units

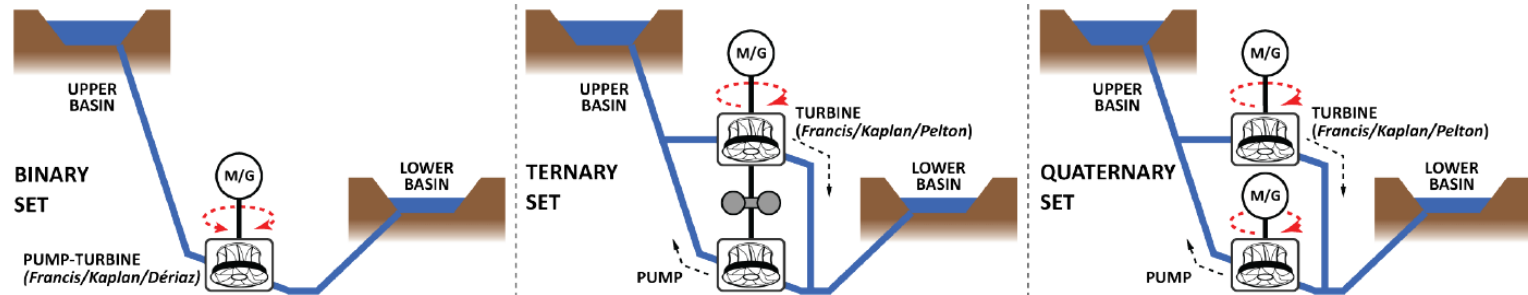

Binary group

Francis-type reversible pump-turbine

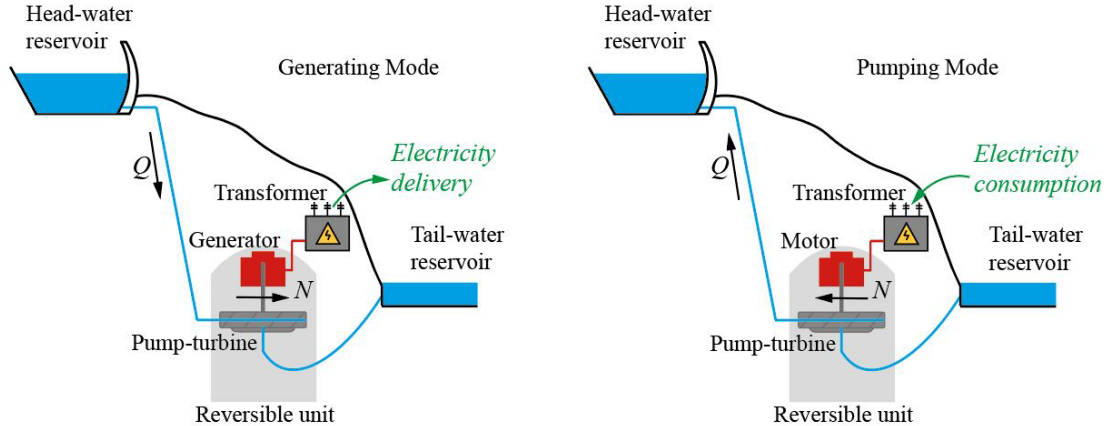

Two machines: electrical machine+ hydraulic machine.

Most common: Francis-type reversible pump-turbine

Used for a total installed power capacity of 7.4 GW in 2018

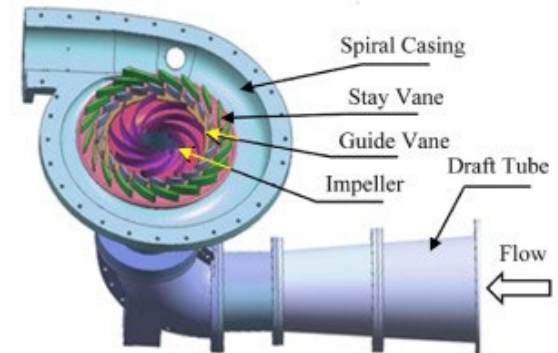

From L1: Specific Hydraulic Energy

Hydraulic Characteristics : generating mode

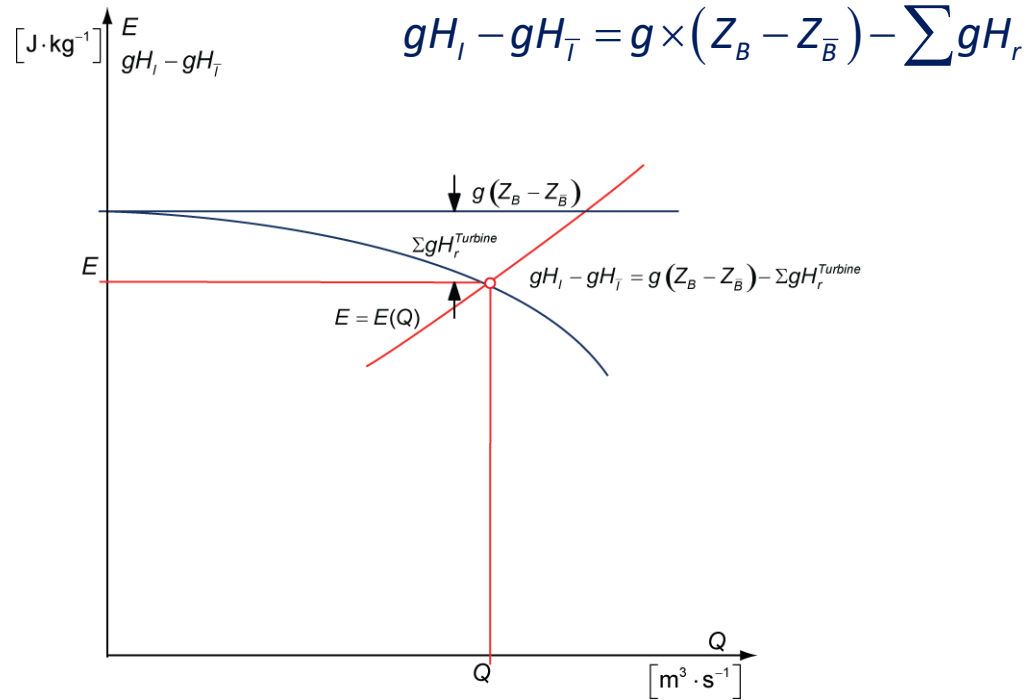

Reversible pump-turbines

Velocity triangles in generating mode

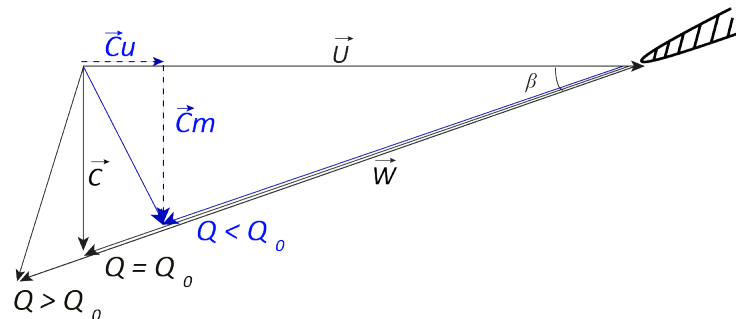
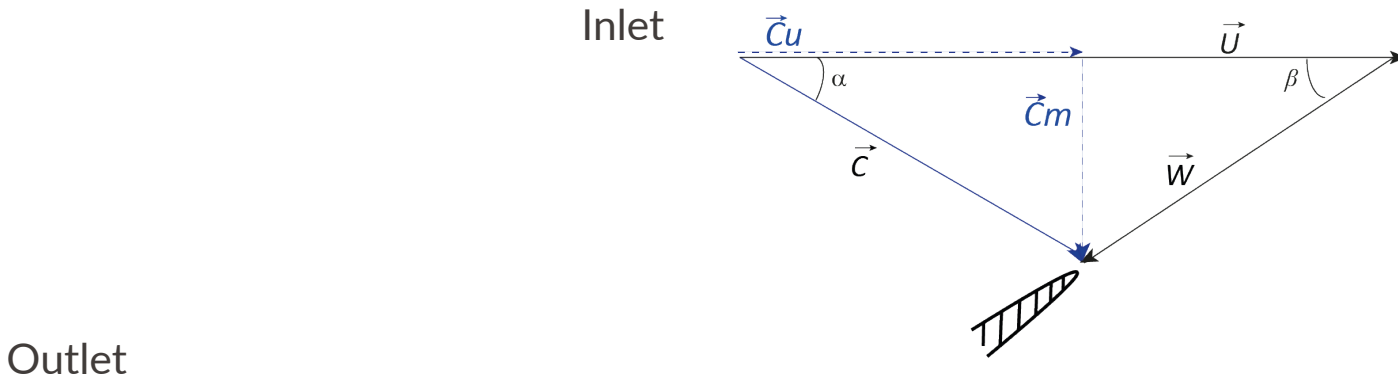

- $Q_0 \rightarrow$ Best Efficiency Point (BEP)
- $Q > Q_0 \rightarrow$ Full Load
- $Q < Q_0 \rightarrow$ Part load

From L1: Specific Hydraulic Energy

Hydraulic Characteristics: pumping mode

$$gH_I - gH_T = g(Z_B - Z_{\bar{B}}) + \sum gH_r$$

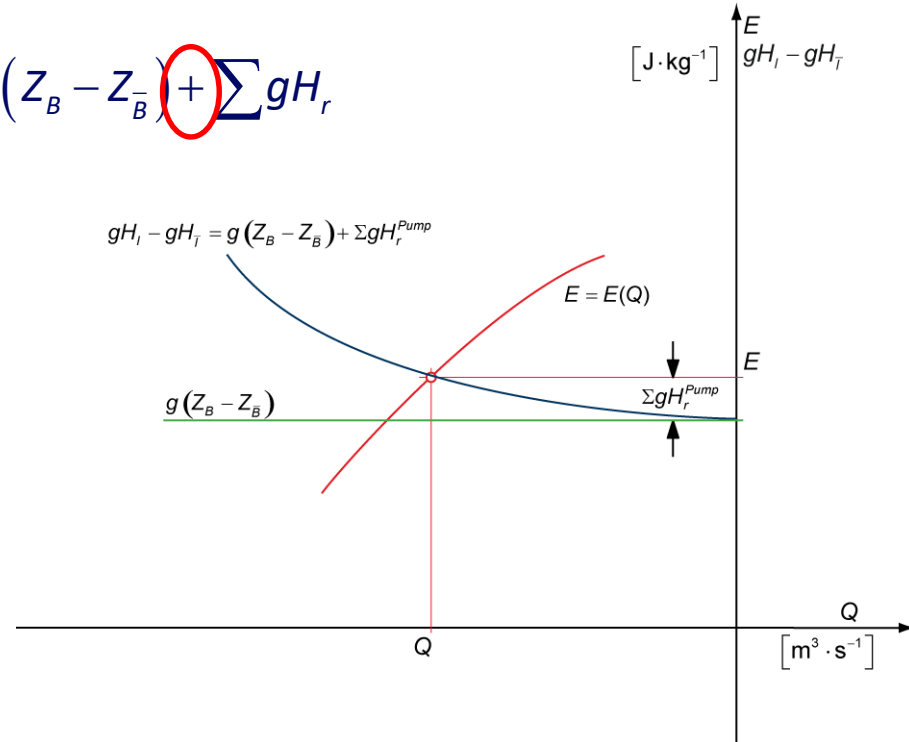

Reversible pump-turbines

Velocity triangles in pumping mode

Inlet

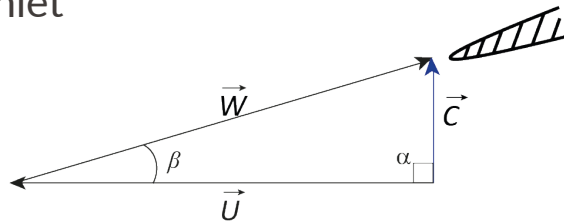

Outlet

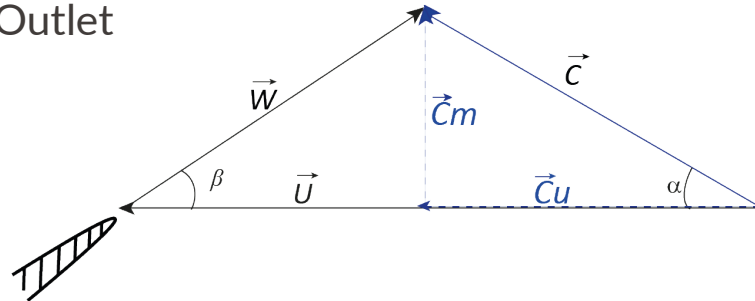

- ✓ Axial Flow at the inlet $Cu_{\bar{1}} = 0$
- ✓ Maximum power \rightarrow at the outlet $Cu_1 = \frac{U_1}{2}$

Reversible pump-turbines

Velocity triangles in pumping mode

Euler equation $E_t = U_1 \cdot Cu_1 - U_{\bar{1}} \cdot Cu_{\bar{1}}$

Inlet Axial Flow $E_t = U_1 \cdot Cu_1 - U_{\bar{1}} \cdot Cu_{\bar{1}}$

Tangential component of the absolute flow velocity $Cu_1 = U_1 - \frac{Cm_1}{\tan \beta_1} = U_1 - \frac{Q}{A_1 \tan \beta_1}$

Transferred specific energy $E_t = U_1^2 - \frac{Q \cdot U_1}{A_1 \tan \beta_1}$

Stored Transferred Power $P_t = \rho Q E_t = \rho Q \left(U_1^2 - \frac{Q \cdot U_1}{A_1 \tan \beta_1} \right)$

Maximum stored Transferred Power $\frac{\partial P_t}{\partial Q} = 0 \rightarrow U_1^2 - \frac{2U_1}{A_1 \tan \beta_1} Q = 0 \rightarrow Q_{opt} = \frac{1}{2} U_1 A_1 \tan \beta_1$

Maximum specific Energy $E_{t,max} = U_1^2 + \frac{Q_{opt} \cdot U_1}{A_1 \tan \beta_1} = U_1^2 - \frac{U_1 A_1 \tan \beta_1}{2 A_1 \tan \beta} U_1 = \frac{U_1^2}{2} \rightarrow Cu_{1,opt} = \frac{U_1}{2}$

$$\rightarrow P_{opt} = \rho A_1 \tan \beta_1 \frac{U_1^3}{4}$$

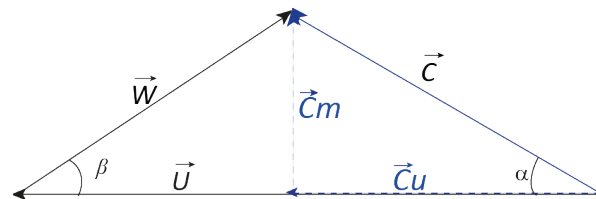

From L2: Classification of Hydraulic Runners

Operating range

- IEC Discharge Factor

$$Q_{ED} = \frac{Q}{D^2 E^{\frac{1}{2}}}$$

- IEC Speed Factor

$$n_{ED} = \frac{nD}{E^{\frac{1}{2}}}$$

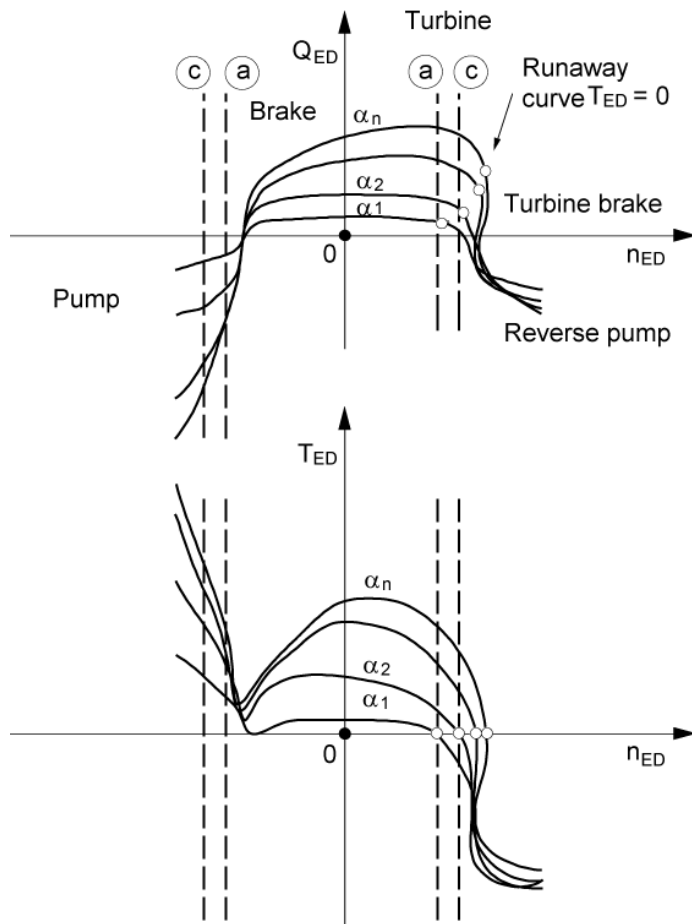

- (a) n_{ED} for E_{Pmax}
- (c) n_{ED} for E_{Pmin}

Constant guide vane angles $\alpha_1, \alpha_2, \dots, \alpha_n$

- (a), (c) Limit of the normal operating range

Variable speed Technology

- Full-size Frequency Converter
 - Max 100 MW
- Double Feed Asynchronous Machines
 - Cylindrical Rotor with Three Phases Winding
 - Slip Rings for Excitation

→ Variable Speed Technology
Enabling Pumping Control

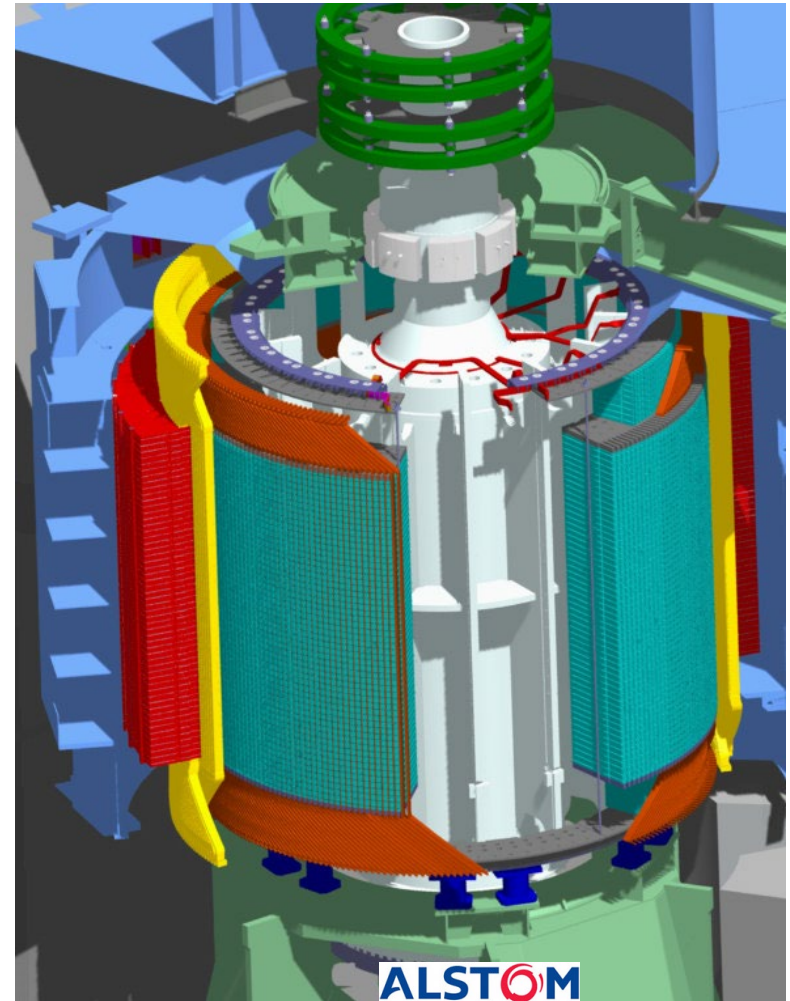

Characteristics Variable speed units

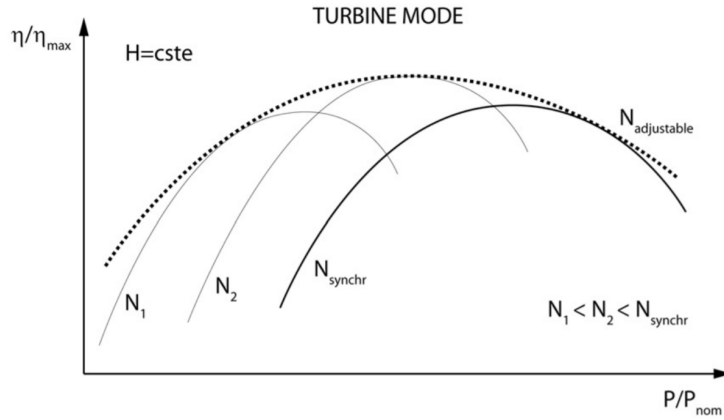

Extended operating range with high performance

Extended operating range
 Allows compensating head variations
 Allows avoiding cavitation

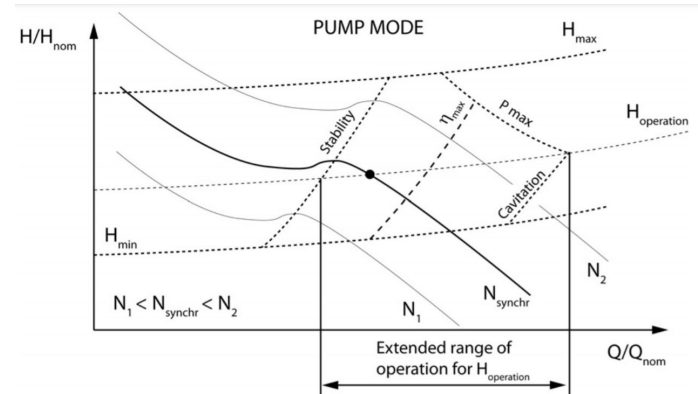

Characteristics Variable speed units

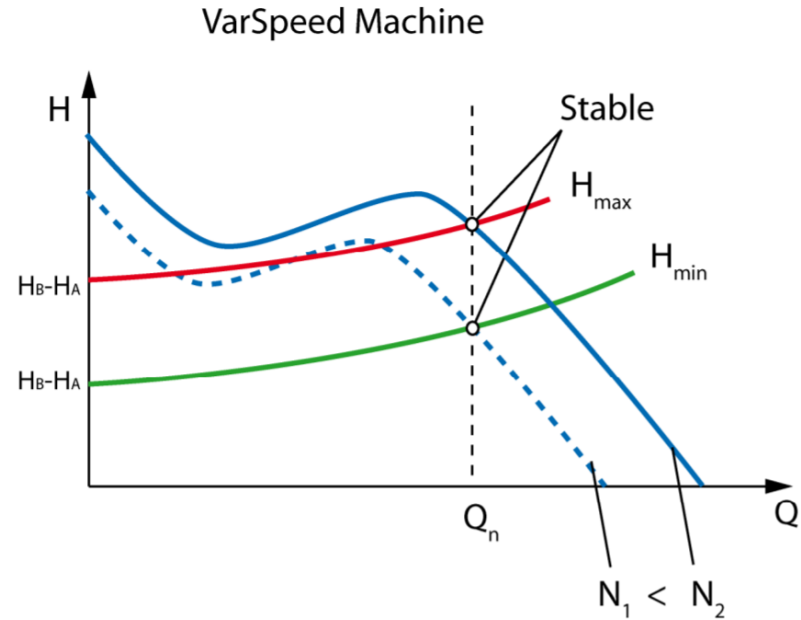
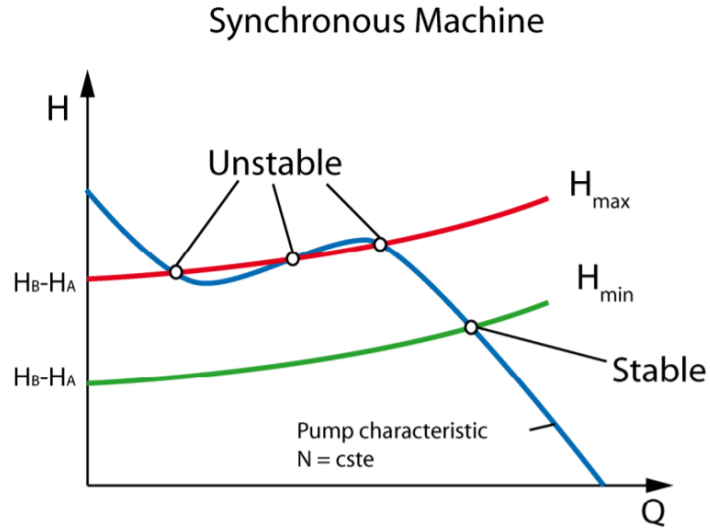

Benefits for variable speed units

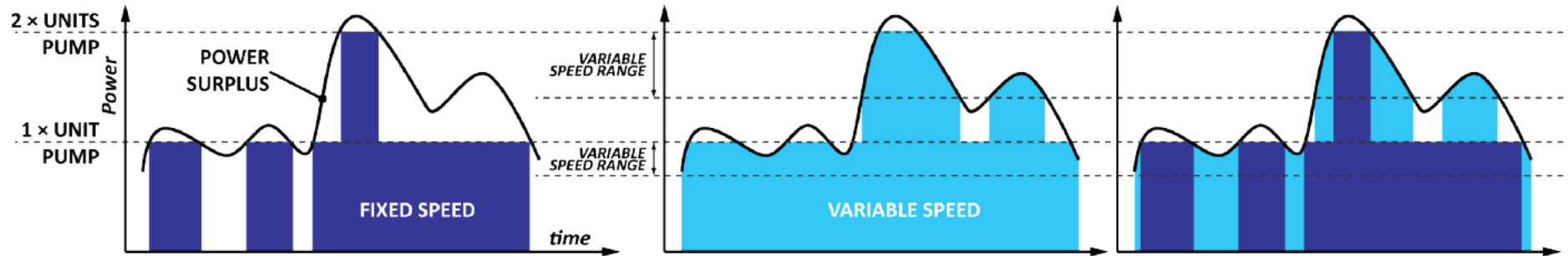

Benefits during transient operations for variable speed units

Fault Right Through:
capability to stay connected in short periods of lower electric network voltage

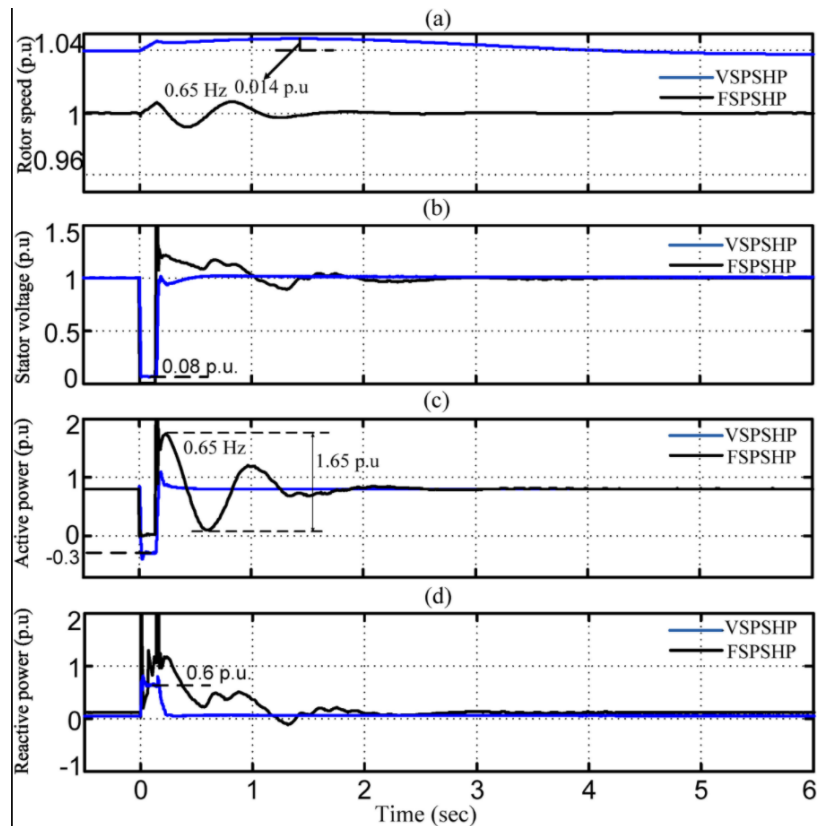

Hydraulic Bypass

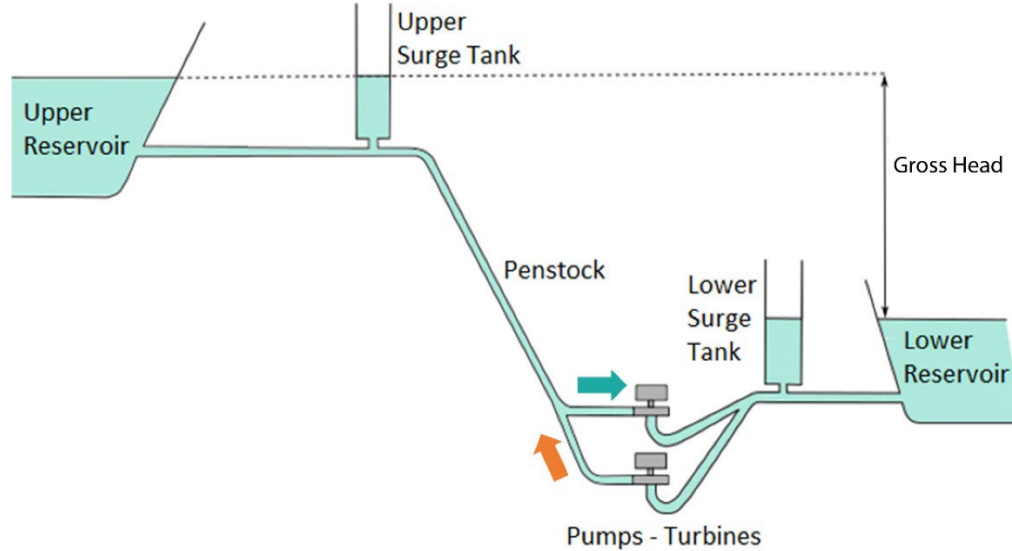

$$P_{TOT} = P^T + P^P$$

Nant de Drance Variable Speed PSP



- Emosson Lake: $210 \cdot 10^6 \text{ m}^3$ Capacity
- Vieil Emosson Lake: $11 \cdot 10^6 \text{ m}^3$ Capacity & 25.5 m Dam Height Increase
- 250 mWC to 390 mWC Head Range
- 6 x 150 MW Single Stage Pump-Turbines
- $428.6 \text{ min}^{-1} \pm 7 \%$ Variable Speed Drive

Reversible Pump-Turbine Units

Advantages:

Fixed speed:

- Compact
- Low investments costs for both civil works and electro-mechanical equipment

With additional variable speed:

- Efficient active power control in pumping mode
- Comply with large head variations
- Extended operating range in turbine and pumping mode
- Fast active power injection in pump and turbine mode Pump start-up without supplementary equipment
- Reactive power control

Disadvantages:

▪ Fixed speed:

- Hydraulic design: trade-off between pumping and generating mode (lower efficiency in respect to standard Francis or Pelton)
- Operating range restricted due to flow instabilities at partial load
- Long start-up time and switch of operating mode

▪ With additional variable speed:

- Investment costs for the electromechanical equipment
- Specific power limited for a given rotational speed

Ternary group

Three machines: electrical machine, hydraulic turbine, pump

They are classified based on the shaft orientation: horizontal or vertical groups

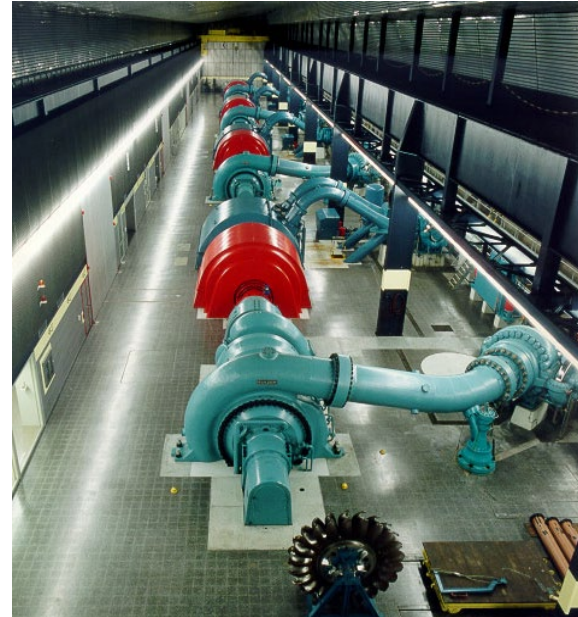
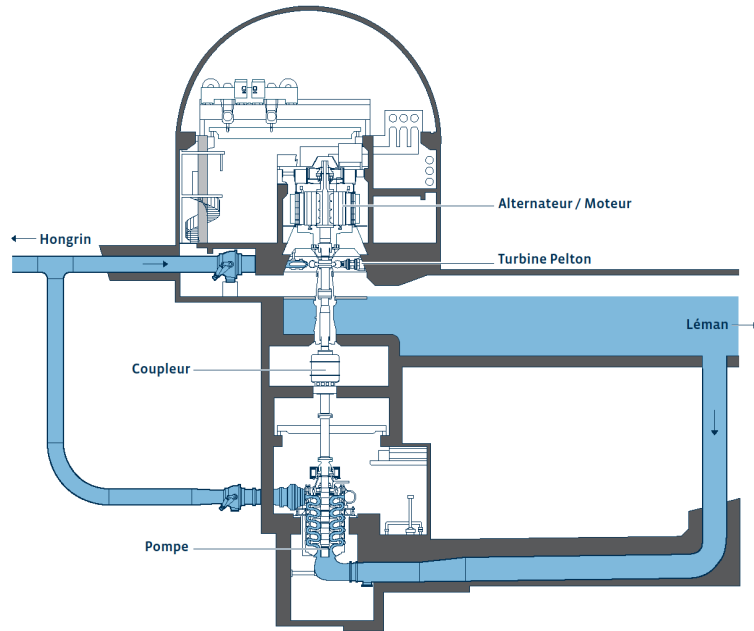

Ternary group

- Usually Pelton + pump
- Matching both Pumping and Generating Modes
 - Length of the Rotating Train;
 - Speed;
 - Required Submergence.
- High Grade Control
 - Pelton Turbine injectors regulation
 - Hydraulic By-Pass
- Turbine Drive for Starting Up
- 1 Direction of Rotation
 - Efficient Cooling
- Safe Transients

Example: Hongrin-Léman PSP

- Hongrin Lake (1969) :
52 millions m³ Capacity
- Veytaux Power Station (1972)
- Veytaux I: 4 Horizontal Ternary Units
 - 256 MW Pumping Power
 - 240 MW Gen. Power
 - 850 mWC Head
 - 600 min⁻¹

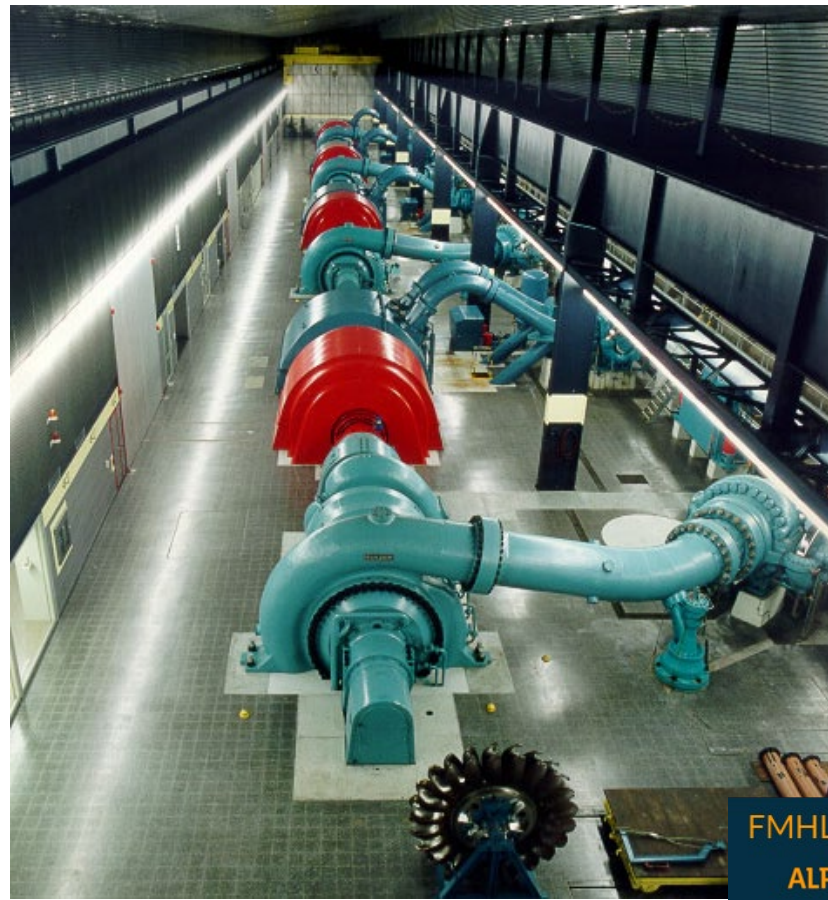

Example: Hongrin-Léman PSP

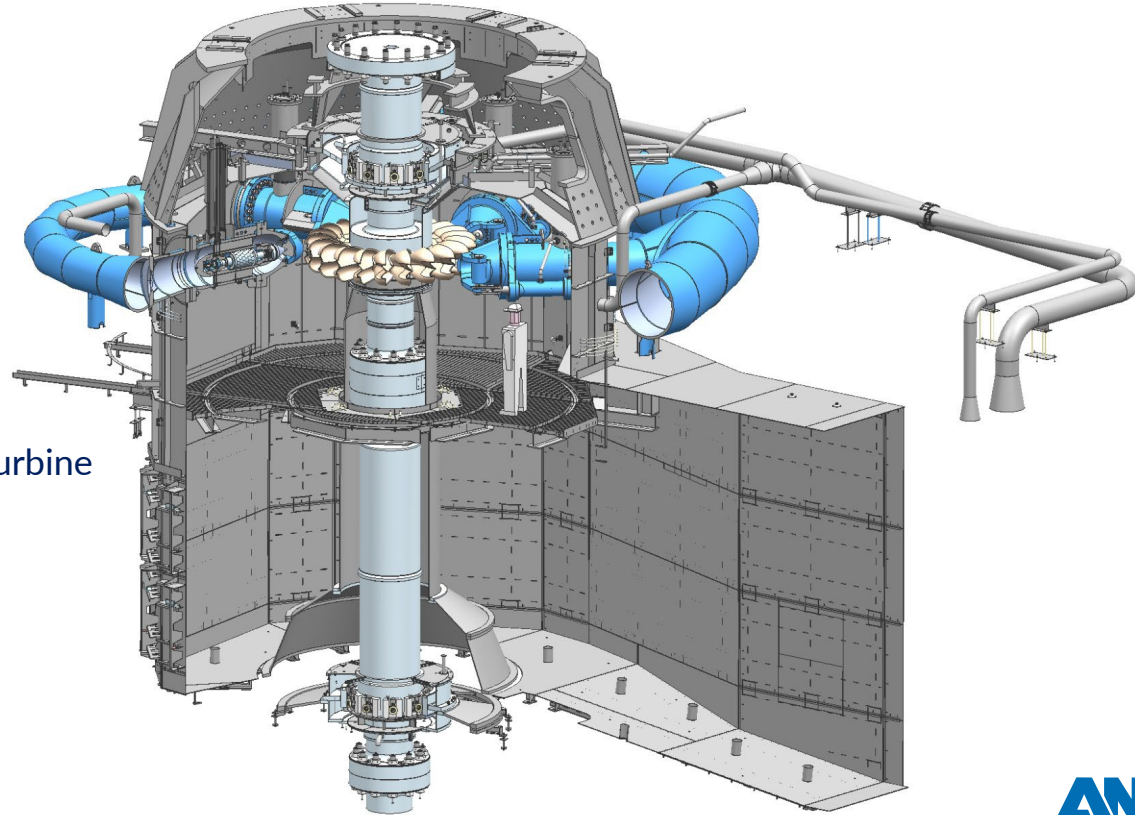

5 Injectors Pelton Turbine

Veytaux II: 2 Vertical Ternary Units

Example: Hongrin-Léman PSP

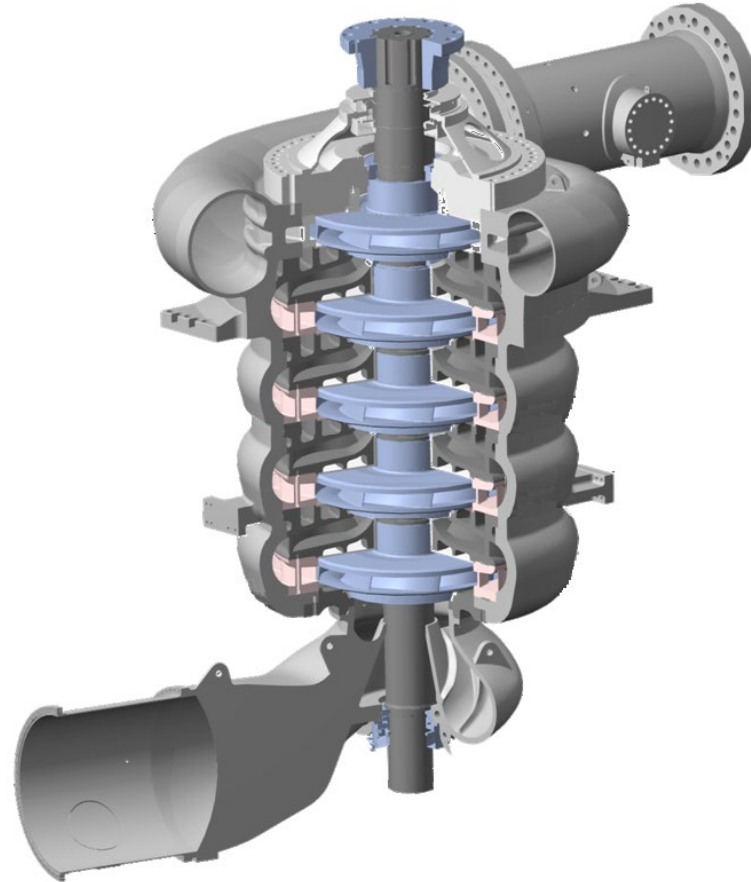

5 Stages Storage Pump

No guide vanes: single operating point (ON/OFF)

Hydraulic Bypass

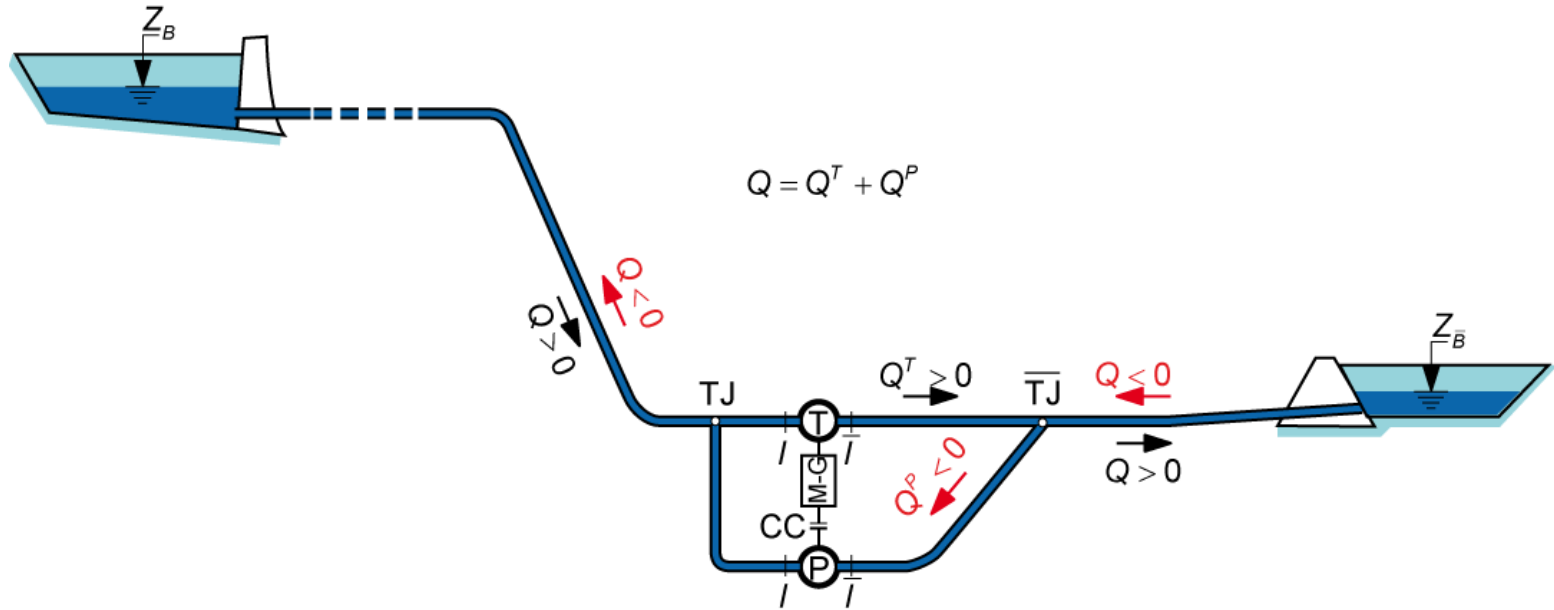

$$P_{TOT} = P^T + P^P$$

Frequency Control through Hydraulic Bypass

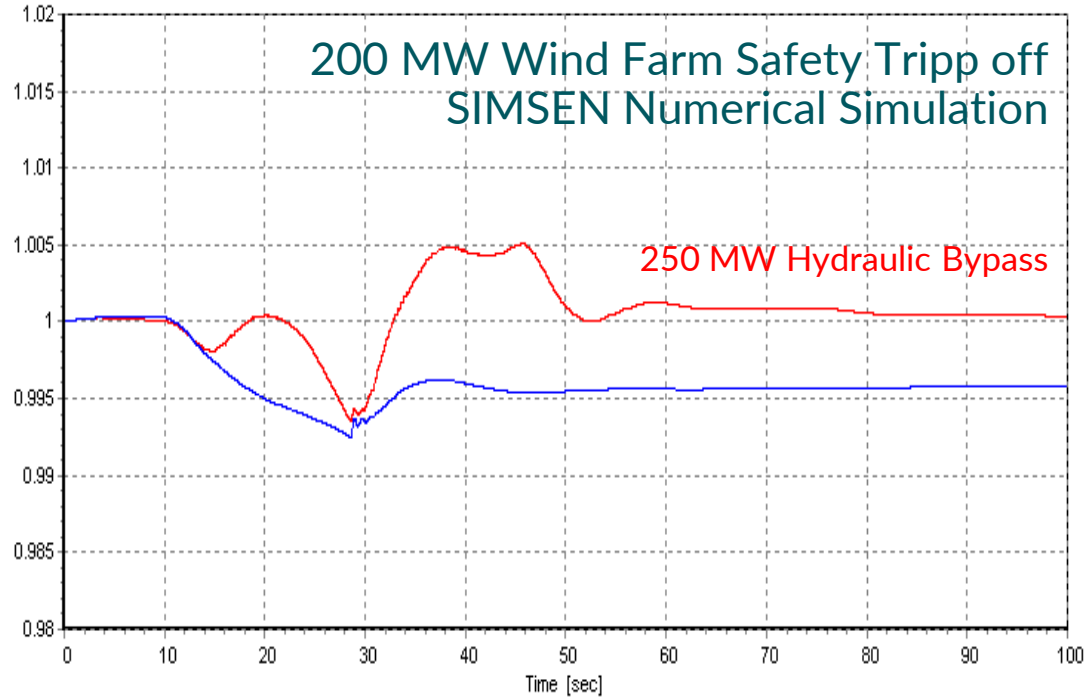

EPFL Ternary groups

Advantages:

- High operational flexibility due to rapid change of operation mode from pump to turbine and vice-versa (same rotating direction)
- Easy and short time start-up in pump mode (start-up with the turbine as drive)
- Adjustable pump power with hydraulic by-pass
- Wide operating range with Pelton turbines
- Increased efficiency in pump and turbine modes (optimal selection of the pump and turbine)
- Proven technology
- Smooth hydraulic transients

Disadvantages:

- High investment costs (civil engineering due to total shaft line length and electromechanical equipment due to numerous components)
- Maintenance costs due to electromechanical complexity and number of components
- Increased ventilation losses in pumping mode due to turbine rotation
- Lower efficiency in case of hydraulic by-pass
- Instability risks for the rotating train for vertical units (long shaft due to low pump submergence).

Comparison for flexibility: binary VS ternary

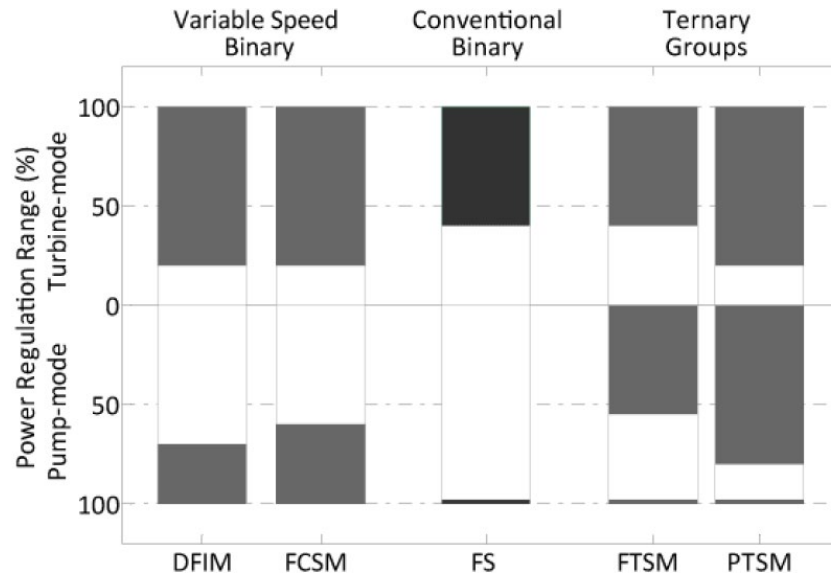

FS: Conventional Fixed-Speed Synchronous Machine;

DFIM: Double Fed Induction Machine;

FCSM: Full Converter Synchronous Machine;

FTSM: Francis Ternary Synchronous Machines with Hydraulic Short Circuit;

PTSM: Pelton Ternary Synchronous Machines with Hydraulic Short Circuit.

Quaternary group

Four Machines: 2 electrical machines, a hydraulic turbine and a pump

Power House Configuration:

1. Consideration of Site Characteristics and Layout.
2. Construction of Two Power Houses:
 - Group 1: Hydraulic Turbines for Generation.
 - Group 2: Pumps for Pumping Purposes.

Turbine Selection:

1. Based on Head and Specific Speed Requirements.
2. Operation Similar to Standard Reservoir Storage Hydropower Plants.

Efficiency Optimization:

1. Each Group Independently Optimized.
2. Maximizing Efficiency for Overall Plant Performance.

Grid Services:

1. Highlighting the Role in Providing Fast Response to Grid Demands.
2. Supporting Grid Stability and Reliability.

Quaternary group

Advantages:

- Optimization for Efficiency: each Group Tailored to Plant Characteristics.
- Fastest Responding Pumped Hydro Technology.

Disadvantages:

- Space requirement for hosting 2 power houses
- Investments costs and maintenance

Grand Maison PSP

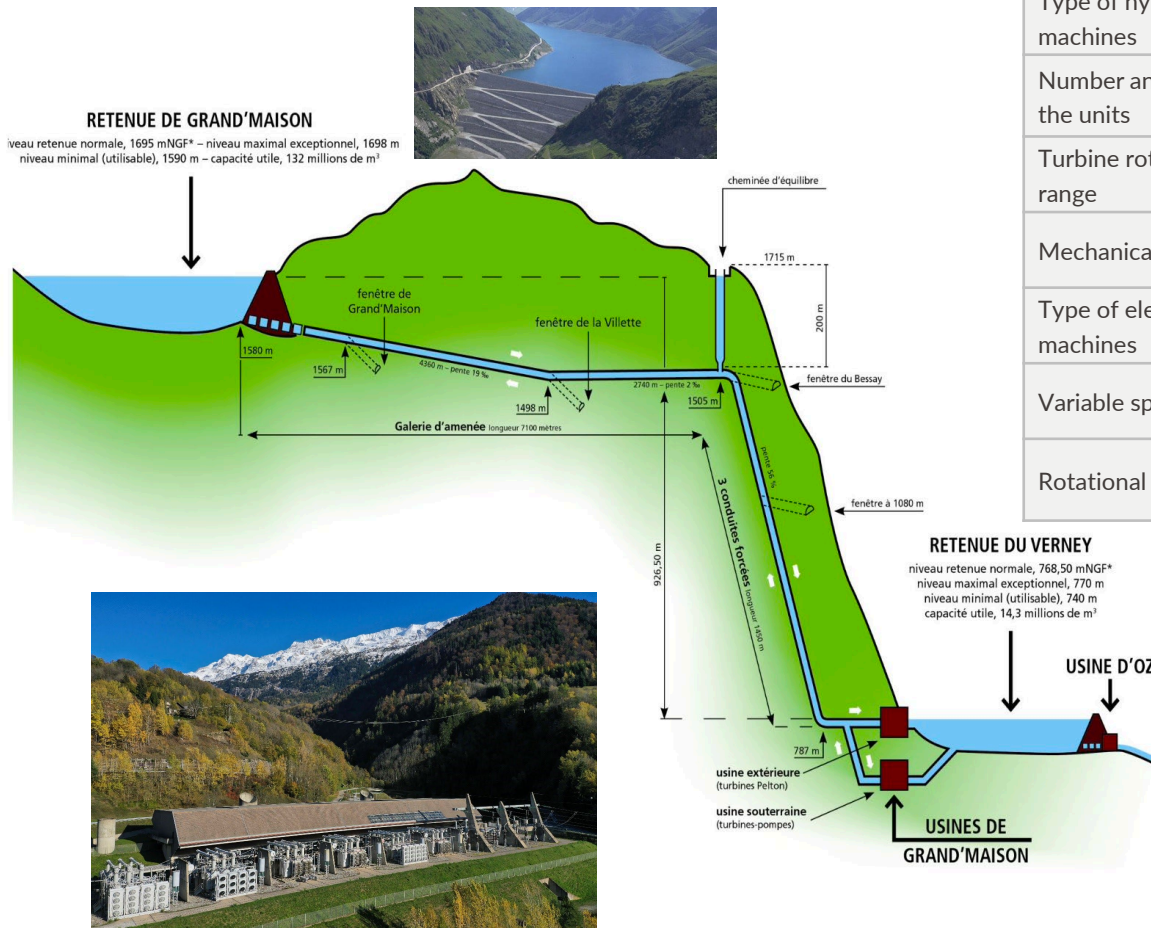

Head	Min 837 m; Rated 900 m; max 923 m
Type of hydraulic machines	Pelton turbines/ Multistage pump turbines
Number and capacity of the units	4 Pelton turbines, 170 MW 8 pump-turbines, 156 MW
Turbine rotational speed range	Fixed speed
Mechanical power	156 MW / unit
Type of electrical machines	12 synchronous machines
Variable speed	Fixed speed
Rotational speed	Pelton Turbine: 428 min ⁻¹ ; Pump-turbine: 600 min ⁻¹ .

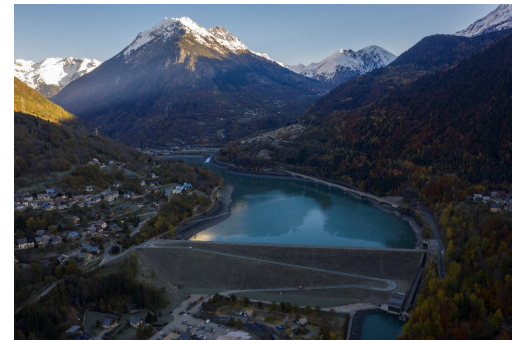

Grand Maison PSP

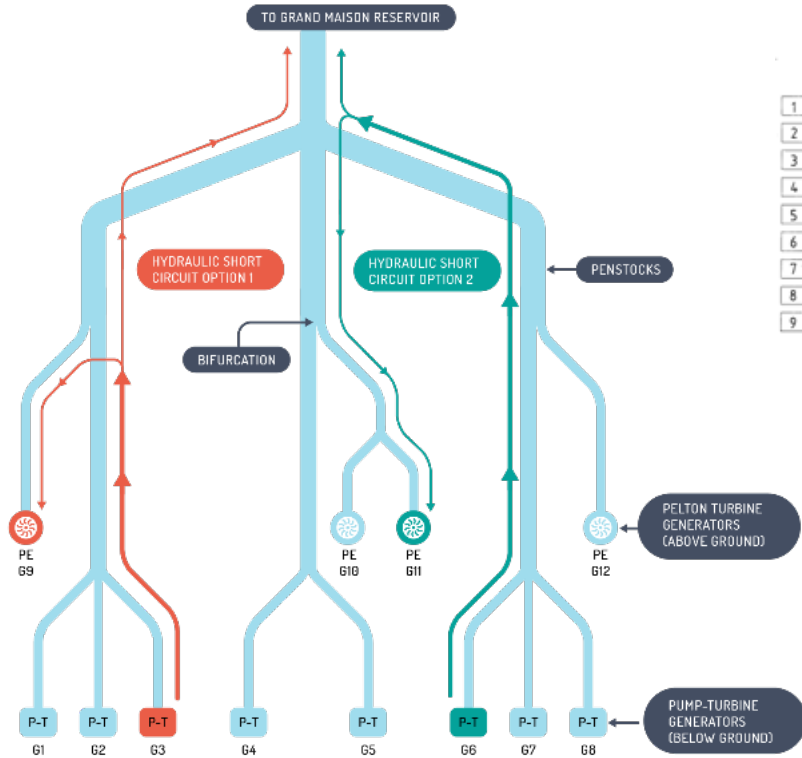

- 1 Usine des groupes Pelton
- 2 Usine des groupes turbines-pompes
- 3 Circulation d'eau des groupes Pelton
- 4 Circulation d'eau des groupes turbines-pompes
- 5 Circulation du personnel
- 6 Puits du matériel
- 7 Sortie des câbles de puissance
- 8 Circulation de chantier
- 9 Galerie de sécurité de l'usine des groupes turbines-pompes et d'accès provisoire au chantier

